

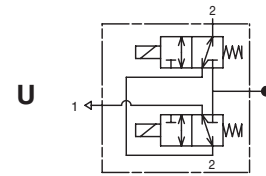

SOLENOID VALVES

redundant, direct operated
basic flow, balanced poppet
1/4



3/2
Series
327

FEATURES

- The redundant solenoid valves are recommended for fail safe pilot applications combining high flow, wide pressure range and absence of minimum operating pressure
- When the redundant valve controls an actuator, the actuator remains in position as long as one of the two solenoid valves (coils) is energized. To exhaust the actuator both solenoids have to be de-energized
- PTFE rider rings and graphite-filled PTFE seals reduce friction and eliminate sticking
- Coils used in metal enclosures have class H insulation materials
- Dedicated execution for low power
- Dedicated execution for extreme low ambient temperatures
- Peak voltage suppression diodes are standard in DC solenoids with metal enclosures
- The solenoid valves satisfy all relevant EC Directives



GENERAL

Differential pressure 0 - 10 bar [1 bar = 100kPa]
Maximum viscosity 65cST (mm²/s)
Response times 75 - 100 ms ⁽¹⁾

fluids ⁽²⁾ (*)	temperature range (TS)	seal materials (*)
air, inert gas, water, oil	-20 to +120°C -40 to + 40°C -50 to + 60°C	FPM (fluoroelastomer) VMQ (silicone) (F)VMQ ((fluoro)silicone)

⁽¹⁾ Energising time for Ex i version booster coils will be < 2 sec (NFIS, WSNFIS and WSCRIS)
⁽²⁾ Air / inert gas only for Ex i version (NFIS, WSNFIS and WSCRIS)

MATERIALS IN CONTACT WITH FLUID

(*) Ensure that the compatibility of the fluids in contact with the materials is verified

	Brass body	Stainless steel body
Body	Brass	AISI 316L SS
Stem	Stainless steel	Stainless steel
Core tube	Stainless steel	Stainless steel
Core and plugnut	Stainless steel	Stainless steel
Springs	Stainless steel	Stainless steel
Sealings & poppets	FPM, VMQ or (F)VMQ	FPM, VMQ or (F)VMQ
Rider ring	PTFE	PTFE

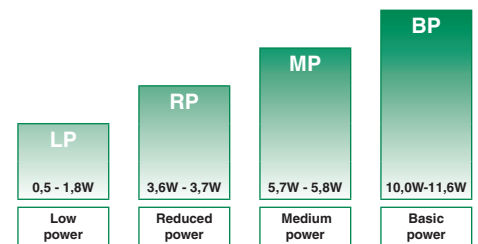
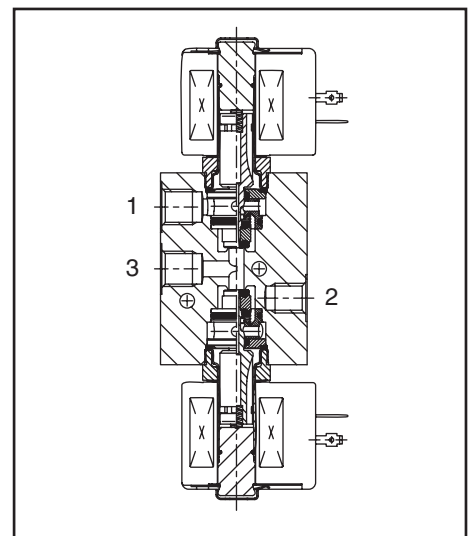

POWER LEVELS - cold electrical holding values (watt)

SPECIFICATIONS

pipe size	orifice size	flow coefficient Kv		operating pressure differential (bar)			power level	prefix optional solenoids								basic catalogue number			
								min.	max. (PS)	air/water (*)	NEMA 7&9	ATEX / IECEx						IP65	
												EF ⁽²⁾	NF	WSCR	NFIS				WSCRIS
❖	(mm)	(m ³ /h)	(l/m)	min.	max. (PS)	air/water (*)	~/=	~/=	EF ⁽²⁾	NF	WSCR	NFIS	WSCRIS	EM	WSCREEM	PV	SC	brass	stainless st.
U - Universal, FPM sealings and poppets																			
1/4	5,7	0,3	5,0	0	10		BP	●	●	-	-	-	●	-	○	●	●	❖ 327B051	❖ 327B052
1/4	5,7	0,3	5,0	0	10		MP	-	●	●	-	-	●	●	-	●	●	❖ 327B251	❖ 327B252
1/4	5,7	0,3	5,0	0	10		RP	-	●	●	-	-	●	●	-	●	●	❖ 327B151	❖ 327B152
1/4	5,7	0,3	5,0	0	10 ⁽²⁾		LP	-	●	●	○	○	-	●	-	-	-	❖ 327B351	❖ 327B352
U - Universal, VMQ sealings and poppets																			
1/4	5,7	0,3	5,0	0	10		BP	●	●	-	-	-	●	-	○	●	●	❖ 327B061	❖ 327B062
U - Universal, (F)VMQ sealings and poppets																			
1/4	5,7	0,3	5,0	0	10		MP	-	●	●	-	-	●	●	-	●	●	❖ 327B261	❖ 327B262
1/4	5,7	0,3	5,0	0	10		RP	-	●	●	-	-	●	●	-	●	●	❖ 327B161	❖ 327B162
1/4	5,7	0,3	5,0	0	10 ⁽²⁾		LP	-	●	●	○	○	-	●	-	-	-	❖ 327B361	❖ 327B362

❖ Select **8** for NPT ANSI 1.20.3 or Select **G** for ISO G(228/1) ● Available feature ○ Available feature in DC only - Not available
⁽²⁾ Air/inert gas only for Ex i version (NFIS, WSNFIS and WSCRIS) ⁽²⁾ Prefix EF and EV should always be used in conjunction with change letter H in the basic number

PREFIX TABLE

prefix							description	power level			
1	2	3	4	5	6	7		LP	RP	MP	BP
E	F						Explosionproof - NEMA 7, 9 - Zinc plated steel conduit	-	-	-	●
E	V						Explosionproof - NEMA 7, 9 - 316 SS conduit	-	-	-	●
E	M						Waterproof IP67 - Metal enclosure (EN/IEC 60079-7+18, 61241-1)*	-	●	●	●
		E	T				Threaded conduit/hole (M20 x 1,5)	●	●	●	●
N	F						Flameproof - Aluminium (EN/IEC 60079-1, 60079-31)*	●	●	●	●
P	V						Encapsulated epoxy moulded (EN/IEC 60079-18, 61241-18)*	-	-	-	○
S	C						Solenoid with spade plug connector (EN/IEC 60730)	-	●	●	●
W	P						Waterproof IP67 - Metal enclosure	-	●	●	●
N	F			I	S		I.S. with Aluminium IP67 enclosure (EN/IEC 60079-11+31)*	○	-	-	-
W	S						Waterproof IP67 - 316 SS enclosure	-	●	●	●
W	S	C	R				Flameproof 316 SS (EN/IEC 60079-0+1+31)*	●	●	●	-
W	S	C	R	E	M		Increased Safety / Encapsulated 316 SS (EN/IEC 60079-0+7+18+31)*	●	●	●	-
W	S	C	R	I	S		Intrinsically Safe 316 SS (EN/IEC 60079-0+11+31)*	○	-	-	-
W	S	E	M				Waterproof IP67 - 316 SS enclosure (EN/IEC 60079-7+18, 61241-1)*	-	●	●	●
W	S	N	F	I	S		I.S. with 316L SS IP67 enclosure (EN/IEC 60079-11+31)*	○	-	-	-
W	S	N	F				Flameproof - 316L SS (EN/IEC 60079-1, 60079-31)*	●	●	●	●
W	S					H	Threaded conduit (1/2" NPT)	●	●	●	●
						C	Class H - Battery charging circuit	-	-	-	●
						X	Other special constructions	-	●	●	●

PRODUCT SELECTION GUIDE

STEP 1

Select basic catalogue number, including pipe thread identification letter. Refer to the specifications table on page 1.

Example: 8327B051

STEP 2

Select prefix (combination). Refer to the specifications table on page 1 and the prefix table on page 2, respect the indicated power level.

Example: NF

STEP 3

Select suffix (combination) if required. Refer to the suffix table on page 2, respect the indicated power level.

Example: CO

STEP 4

Select voltage. Refer to standard voltages on page 3.

Example: 230V / 50/60 Hz

STEP 5

Final catalogue / ordering number.

Example:

NF 8327B051 CO 230V / 50/60 Hz

SUFFIX TABLE

suffix					description	power level			
1	2	3	4	5		LP	RP	MP	BP
N	V				FPM (fluoroelastomer) and parts cleaned for oxygen service	●	●	●	●
V					FPM (fluoroelastomer)	●	-	-	-
C	O				Epoxy coating on all external surfaces	●	●	●	●

● Available feature

○ Available feature in DC only

- Not available

* ATEX solenoids are also approved according to EN 13463-1 (non electrical valves)

(1) Functional Safety certification is not applicable with this feature

OPTIONS & ACCESSORIES

catalogue number	spare part kit no. ⁽²⁾	mounting bracket
	~ / =	
SC ❖ 327B051	C123670	■
SC ❖ 327B052	C123670	■
SC ❖ 327B061	C131237	■
SC ❖ 327B062	C131237	■
SC ❖ 327B151	C132251	■
SC ❖ 327B152	C132251	■
SC ❖ 327B161	C132253	■
SC ❖ 327B162	C132253	■
SC ❖ 327B251	C132251	■
SC ❖ 327B252	C132251	■
SC ❖ 327B261	C132253	■
SC ❖ 327B262	C132253	■
SC ❖ 327B351	C132443	■
SC ❖ 327B352	C132443	■
SC ❖ 327B361	C132444	■
SC ❖ 327B362	C132444	■

❖ Select 8 for NPT ANSI 1.20.3 or select G for ISO G(228/1)

(2) Standard prefixes/suffixes are also applicable to kits

■ Mounting holes in body

ORDERING EXAMPLES VALVES:

SC	8	327B051	CO	24V / DC
WSEMT	G	327B052	CO	24V / DC
NFET	G	327B051	CO	230V / 50/60 Hz
WSEM	G	327B052	CO	24V / DC
NF	8	327B261	CO	24V / DC
WSCR	G	327B051	CO	24V / DC
EM	8	327B251	CO	230V / 50/60 Hz
PV	8	327B062	CO	24V / DC
EF	G	327H152	CO	240V / 50/60 Hz

prefix⁽³⁾ pipe thread basic number⁽³⁾ voltage suffix

ORDERING EXAMPLES KITS*:

WS	C131237 ⁽⁴⁾	
EM	C123670	
PV	C131237	
EF	C123670	CO

prefix basic number suffix

(3) Prefix EF and EV should always be used in conjunction with change letter H in the basic number

(4) Basic kit number applies to SC coil construction

* Because of the nature of redundant valves (2x solenoid) the spare part kits have to be ordered 2x

EXPLANATION OF TEMPERATURE RANGES OF SOLENOID VALVES

Valve temperature range	The valve temperature range (TS) is determined by the selected seal material, the temperature range for proper operation of the valve and sometimes by the fluid (e.g. steam)
Operator ambient temperature range	The operator ambient temperature range is determined by the selected power level and the safety code
Total temperature range	The temperature range of the complete solenoid valve is determined by the limitations of both temperature ranges above

ELECTRICAL CHARACTERISTICS

Coil insulation class	H
Electrical safety	IEC 335
Standard voltages ⁽¹⁾	DC (=) 24V - 48V; Allowable voltage variation ± 10% AC (~) 24V - 48V - 115V - 230V/50/60Hz; Other voltages are available on request

prefix option	power ratings				operator ambient temperature range (C°) ⁽²⁾	safety code	electrical enclosure protection (EN 60529)	replacement coil / kit		type ⁽³⁾
	inrush ~	holding ~	hot/cold =					~	=	
	(VA)	(VA)	(W)	(W)				230V/50/60 Hz	24V/DC	
Basic power (BP)										
SC	10,0	10,0	10,0	9,0/11,2	-40 to +55	EN 60730	IP65, moulded	123664-017	400425-142	01
WP/WS	10,0	10,0	10,0	9,0/11,2	-40 to +55	EN 60730	IP67, steel /SS	400915-017	400913-142	03
NF/WSNF	10,0	10,0	10,0	9,0/11,2	-60 to +40/60	II2G Ex d IIC Gb T6/T5, II2D Ex t IIIC Db	IP67, alu./SS	400915-017	400913-142	05
EM/WSEM	10,0	10,0	10,0	9,0/11,2	-40 to +40	II2G Ex e mb IIC Gb T3, II2D Ex tb IIIC Db	IP67, steel /SS	400915-017	400913-142	03
PV	-	-	-	9,0/11,2	-40 to +55	II2G Ex mb IIC Gb T4, II2D Ex mb IIIC Db	IP67, moulded	-	- ⁽⁴⁾	07
EF/EV	12,0	12,0	12,0	9,3/11,6	-40 to +52/40	NEMA type 7 and 9	NEMA 4X	276002-058D	238714-006D	08
Medium Power (MP)										
SC	5,8	5,8	5,8	5,2/5,7	-40 to +90	EN 60730	IP65, moulded	400924-297	400923-442	02
WP/WS	5,8	5,8	5,8	5,2/5,7	-40 to +90	EN 60730	IP67, steel /SS	400921-297	400914-442	04
NF/WSNF	5,8	5,8	5,8	5,2/5,7	-60 to +40/75	II2G Ex d IIC Gb T6/T5/T4, II2D Ex t IIIC Db	IP67, alu./SS	400921-297	400914-442	05
WSCR	5,8	5,8	5,8	5,2/5,7	-60 to +90	II2G Ex d IIC Gb T6/T4, II2D Ex t IIIC Db	IP66/67, SS	400962-297	400961-442	06
WSCREM	5,8	5,8	5,8	5,2/5,7	-60 to +60/75/90	II2G Ex e mb IIC Gb T6/T4, II2D Ex tb IIIC Db	IP66/67, SS	400962-297	400961-442	06
EM/WSEM	5,8	5,8	5,8	5,2/5,7	-40 to +40/75/90	II2G Ex e mb IIC Gb T5/T4/T3, II2D Ex tb IIIC Db	IP67, steel /SS	400921-297	400914-442	04
Reduced Power (RP)⁽⁵⁾										
SC	3,7	3,7	3,7	3,2/3,6	-40 to +55	EN 60730	IP65, moulded	- ⁽⁵⁾	400923-042	02
WP/WS	3,7	3,7	3,7	3,2/3,6	-40 to +55	EN 60730	IP67, steel /SS	- ⁽⁵⁾	400914-242	04
NF/WSNF	3,7	3,7	3,7	3,2/3,6	-60 to +60	II2G Ex d IIC Gb T6, II2D Ex t IIIC Db	IP67, alu./SS	- ⁽⁵⁾	400914-242	05
WSCR	3,7	3,7	3,7	3,2/3,6	-60 to +40/60/90	II2G Ex d IIC Gb T6/T5/T4, II2D Ex t IIIC Db	IP66/67, SS	- ⁽⁵⁾	400961-242	06
WSCREM	3,7	3,7	3,7	3,2/3,6	-60 to +40/60/90	II2G Ex e mb IIC Gb T6/T5/T4, II2D Ex tb IIIC Db	IP66/67, SS	- ⁽⁵⁾	400961-242	06
EM/WSEM	3,7	3,7	3,7	3,2/3,6	-40 to +40/55	II2G Ex e mb IIC Gb T6/T5, II2D Ex tb IIIC Db	IP67, steel /SS	- ⁽⁵⁾	400914-242	04
Low Power (LP)⁽⁵⁾										
NF/WSNF	1,85	1,85	1,85	1,5/1,8	-60 to +55	II2G Ex d IIC Gb T6, II2D Ex t IIIC Db	IP67, alu./SS	- ⁽⁵⁾	400914-542	05
NFIS ⁽⁶⁾	0,5	0,5	0,5	0,5	-40 to +60	II2G Ex ia IIC T6 Gb, II2D Ex tb IIIC Db	IP66/67, alu./SS	- ⁽¹⁾	429013-001	05
WSCRIS	0,5	0,5	0,5	0,5	-40 to +60	II2G Ex ia IIC T6 Gb, II2D Ex tb IIIC Db	IP66/67, SS	- ⁽¹⁾	429013-001	06
WSNFIS	0,5	0,5	0,5	0,5	-40 to +60	II2G Ex ia IIC T6 Gb, II2D Ex tb IIIC Db	IP66/67, alu./SS	- ⁽¹⁾	429013-001	05

⁽¹⁾ NFIS, WSNFIS and WSCRIS only available in 24V/DC ⁽²⁾ Temperature range can be limited by sealings ⁽³⁾ Refer to the dimensional drawings on page 4 and 5
⁽⁴⁾ Multiple coil kits are available under ATEX/IECEx, contact us ⁽⁵⁾ AC (~) limited to 127V/50/60Hz or 125V/DC ⁽⁶⁾ Shall be protected against any impact or friction, see the installation conditions given in the I&M sheet
 - Not available

ELECTRICAL CONNECTIONS

prefix	connection
SC	Spade plug connector with cable gland EN175301-803A (ISO 4400) for cables with an outer diameter from 6 to 10 mm
WP, WS, EM, WSEM, NFIS, WSNFIS, WSCRIS	M20 plastics cable gland for cables with an outer diameter from 7 to 12 mm.
WSCREM	M20 316 SS cable gland for cables with an outer diameter from 7,2 to 11,7 mm.
NF, WSNF, WSCR, NFTIS, WSNFTIS	1/2" NPT threaded cable entry. Enclosures are supplied without cable gland
NFET, WSNFET, NFETIS, WSNFETIS	M20 x 1,5 threaded cable entry. Enclosures are supplied without cable gland

ADDITIONAL OPTIONS

- Direct mount / pad mount construction according to NAMUR recommendations
- Ex mb/mD (prefix "PV") solenoid can be supplied with various cable lengths
- Compliance with "UL", "CSA" and other local approvals available on request
- Special moulded-in solid state components for peak voltage suppression and/or rectification (four diode bridge)

INSTALLATION

- Multi language installation/maintenance instructions are included with each valve
- The solenoid valves can be mounted in any position without affecting operation
- The mounting holes are provided in the valve body
- Threaded pipe connection identifier is 8 = NPT (ANSI 1.20.3); G = G (ISO 228/1)
- Declarations of conformity are available on request
- Ex e mb Prefix "EM" and Ex ia Prefix "NFIS/WSCRIS" execution: solenoid enclosure has a cable gland with integral strain relief for cables with an o.d. from 7 to 12 mm and is provided with an internal and external connection facility for an earthing or bonding conductor
- Ex d Prefix "NF/WSNF/WSCR" enclosure is provided with a 1/2" NPT threaded entry hole, M20 x 1,5 (prefix "ET") is optional. These are supplied without cable gland
- All DC solenoids with metal enclosure are provided with switch-off peak voltage suppression diodes
- To comply with IEC 61508 (SIL) the valves must be provided with a specific exhaust protector (as shown on page 6) or equal

DIMENSIONS (mm), WEIGHT (kg)



TYPE 01:
Epoxy moulded
SC: IEC 335 / ISO 4400

327B051 / B052 / B061 / B062

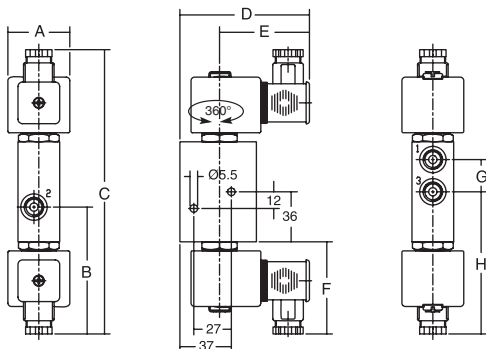

TYPE 02:
Epoxy moulded
SC: IEC 335 / ISO 4400

327B151 / B152 / B161 / B162 / B251 / B252 / B261 / B262

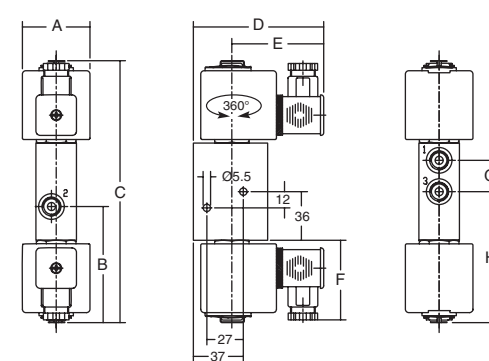

TYPE 03:
Metal, epoxy coated / AISI 316 SS
WP / WS: IEC 335
EM / WSEM: EN/IEC 60079-7+18, 61241-1

327B051 / B052 / B061 / B062

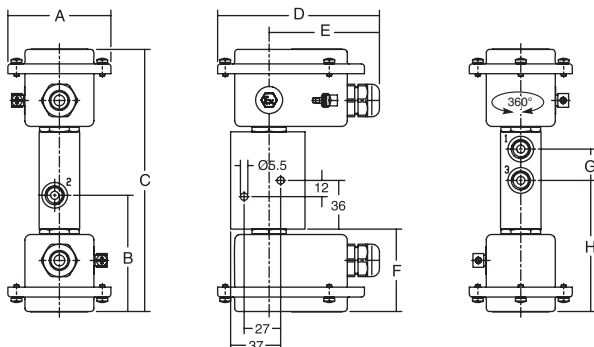

TYPE 04:
Metal, epoxy coated / AISI 316 SS
WP / WS: IEC 335
EM / WSEM: EN/IEC 60079-7+18, 61241-1

327B151 / B152 / B161 / B162 / B251 / B252 / B261 / B262

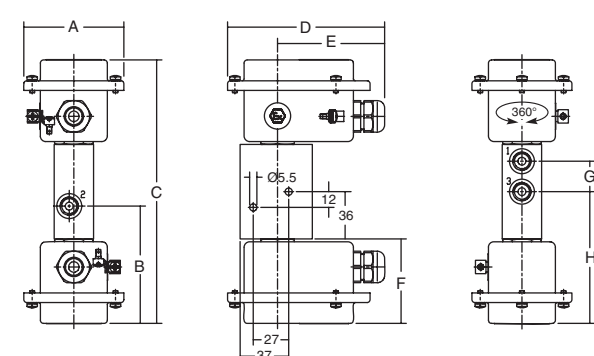

DIMENSIONS (mm), WEIGHT (kg)



TYPE 05:
Aluminium, epoxy coated / AISI 316L SS
NF/WSNF : EN/IEC 60079-1, 60079-31
NFIS/WSNFIS : EN/IEC 60079-11, 60079-31

327B051 / B052 / B061 / B062 / B151 / B152 / B161 / B162 /
B251 / B252 / B261 / B262 / B351 / B352 / B361 / B362

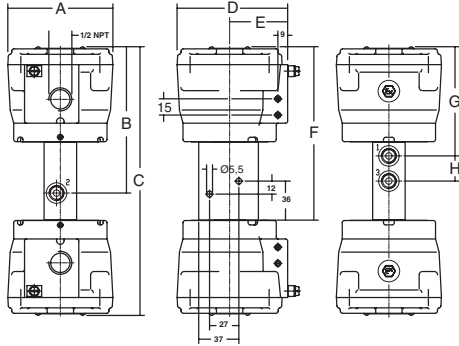

TYPE 06:
AISI 316L SS
WSCR : EN/IEC 60079-0, 60079-1, 60079-31
WSCREM : EN/IEC 60079-0, 60079-7, 60079-18,
EN/IEC 60079-31
WSCRIS : EN/IEC 60079-0, 60079-11, 60079-31

327B151 / B152 / B161 / B162 / B351 / B352 / B361 / B362

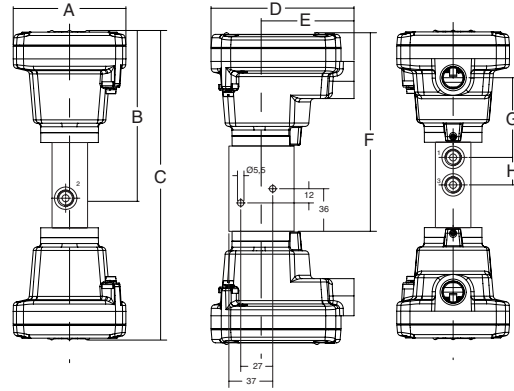

TYPE 07:
Epoxy encapsulated
PV: EN/IEC 60079-18, 61241-18

327B051 / B052 / B061 / B062

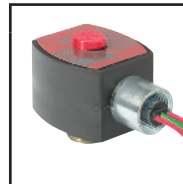
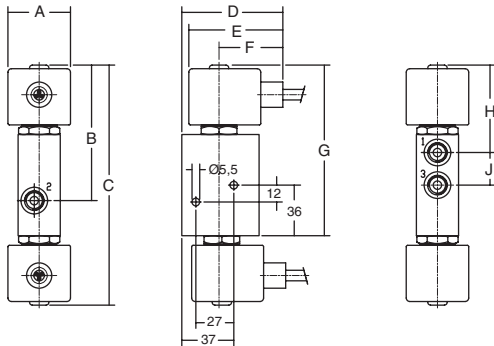

TYPE 08:
Epoxy encapsulated
EF and EV: NEMA type 7, 9 / ICS-6 ANSI

327H001 / H002 / H011 / H012

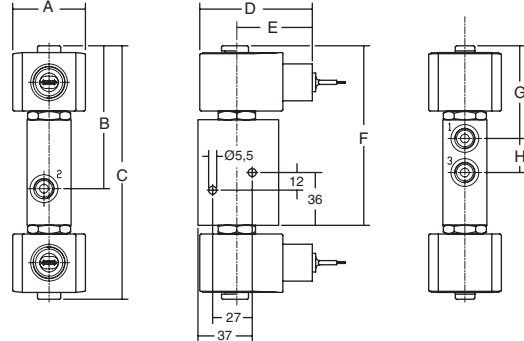

type	prefix/option	power level	A	B	C	D	E	F	G	H	weight
01	SC	BP	45	91	205	93	65	66	23	102	1,55 kg
02	SC	MP/RP	50	86	194	97	68	59	23	97	1,65 kg
03	WP, WS, EM, WSEM	BP	76	86	194	120	82	61	23	97	1,60 kg
04	WP, WS, EM, WSEM	MP/RP	76	90	201	120	82	63	23	100	1,70 kg
05	NF, WSNF	BP/MP/RP	97	135	248	102	54	160	101	23	4,70 kg
05	NF, WSNF, NFIS, WSNFIS	LP	97	145	268	102	54	170	111	23	4,90 kg
06	WSCR, WSCREM, WSCRIS	RP/LP	92	137	252	116	75	161	103	23	3,10 kg
07	PV	BP	45	97	171	72	67	45	121	23	1,70 kg
08	EF, EV	BP	50	97	173	77	51	122	62	23	1,70 kg

SECTIONAL DRAWING

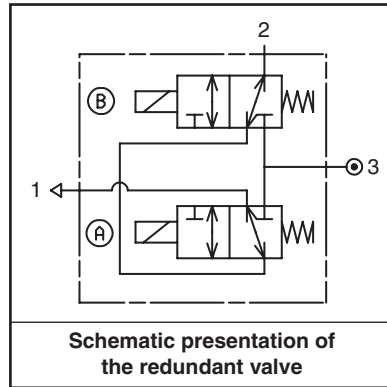
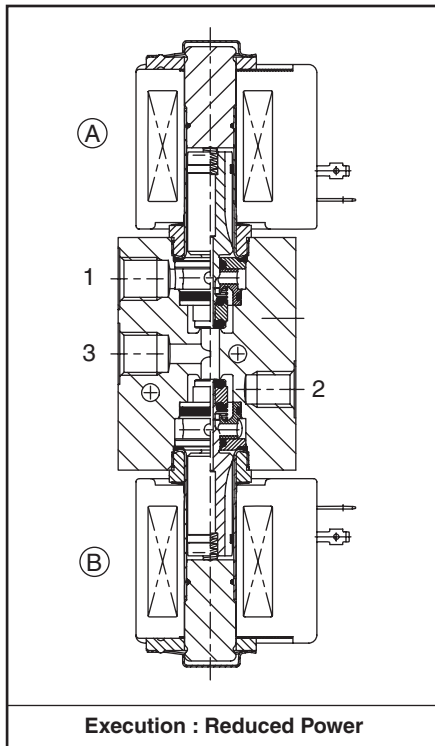

NF/WSNF MOUNTING BRACKET

