

## FEATURES

- The valves are certified according to IEC 61508 Functional Safety data and have SIL-3 capability (Exida certification)
- The solenoid valves are recommended for pilot applications with high flow, wide pressure ranges and no minimum operating pressure
- Coils used in metal enclosures have class H insulation materials
- The core movement is guided to ensure optimal alignment. The special low friction seal accomplishes a balanced construction at the specified temperature and pressure range at minimum power levels
- Special rider rings eliminate sticking and provide exceptional service life
- No minimum operating pressure required
- Pressure can be applied at any port
- 316L stainless steel construction for highly corrosive atmospheres
- The solenoid valves satisfy all relevant EC Directives
- Manual Operators are optional including an under pressure removable type
- Environmental NACE compliant and certified vibration resistant in combination with WSCR solenoids



## GENERAL

**Differential pressure** 0 - 10 bar [1 bar = 100kPa]  
**Response times** < 100 ms

fluids (*)	temperature range (TS) <sup>(1)</sup>	seal materials (*)
air, inert gas	- 25 to + 60°C - 10 to + 90°C - 50 to + 60°C	NBR (nitrile) FPM (fluoroelastomer) (F)VMQ ((fluoro)sillicone)

<sup>(1)</sup> Can be limited by the operator ambient temperature range for explosion proof solenoids

## MATERIALS IN CONTACT WITH FLUID

(\*) Ensure that the compatibility of the fluids in contact with the materials is verified

	Brass body	Stainless steel body
<b>Body</b>	Brass	AISI 316L SS
<b>Stem</b>	Stainless steel	Stainless steel
<b>Core tube</b>	Stainless steel	Stainless steel
<b>Core and plugnut</b>	Stainless steel	Stainless steel
<b>Springs</b>	Stainless steel	Stainless steel
<b>Seals</b>	NBR, FPM or (F)VMQ	NBR, FPM or (F)VMQ
<b>Rider ring</b>	PTFE	PTFE

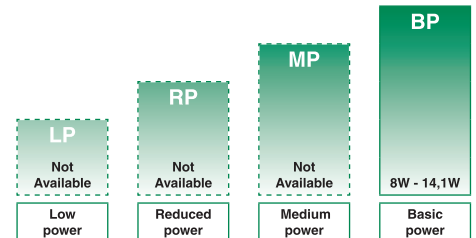
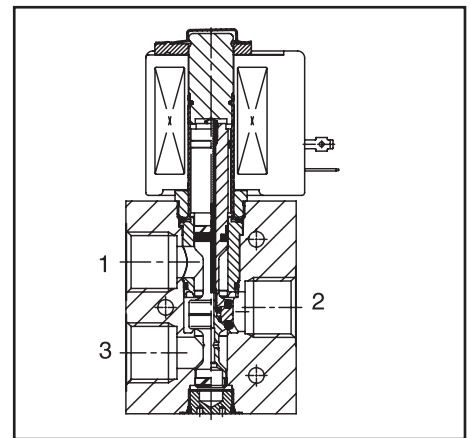

POWER LEVELS - cold electrical holding values (watt)

## SPECIFICATIONS

pipe size	orifice size	flow coefficient Kv		operating pressure differential (bar)		power level	prefix optional solenoids							basic catalogue number		
							min.	max. (PS)	NEMA 7&9	ATEX/IECEX			IP65			
										air (*)	Ex d	Ex e mb				Ex mb
❖	(mm)	(m³/h)	(l/m)			~/=	~/=	EF	NF	WSCR	EM	WCREM	PV	SC	brass	stainless steel
<b>U - Universal, NBR sealings and poppets</b>																
1/4	12	1,5	25,0	0	10	BP	-	●	●	●	●	-	●	❖ 327A647	❖ 327A648	
1/2	12	1,5	25,0	0	10	BP	-	●	●	●	●	-	●	❖ 327A607	❖ 327A608	
<b>U - Universal, FPM sealings and poppets</b>																
1/4	12	1,5	25,0	0	10	BP	-	●	●	●	●	-	●	❖ 327A649	❖ 327A650	
1/2	12	1,5	25,0	0	10	BP	-	●	●	●	●	-	●	❖ 327A609	❖ 327A610	
<b>U - Universal, (F)VMQ sealings and poppets</b>																
1/4	12	1,5	25,0	0	10	BP	-	●	●	●	●	-	●	❖ 327A645	❖ 327A646	
1/2	12	1,5	25,0	0	10	BP	-	●	●	●	●	-	●	❖ 327A605	❖ 327A606	

❖ Select **8** for NPT ANSI 1.20.3 or Select **G** for ISO G(228/1)      ● Available feature      ○ Available feature in DC only      - Not available

## PREFIX TABLE

prefix							description	power level			
1	2	3	4	5	6	7		LP	RP	MP	BP
E	M						Waterproof IP66/67 - Metal enclosure (EN/IEC 60079-7,-18 and -31)* Threaded conduit/hole (M20 x 1,5)	-	-	-	●
N	F						Flameproof - Aluminium (EN/IEC 60079-1, 60079-31)*	-	-	-	●
S	C						Solenoid with spade plug connector (EN/IEC 60730)	-	-	-	●
W	P						Waterproof IP67 - Metal enclosure	-	-	-	●
W	S						Waterproof IP67 - 316 SS enclosure	-	-	-	●
W	S	C	R				Flameproof 316L SS (EN/IEC 60079-0+1+31)*	-	-	-	●
W	S	C	R	E	M		Increased Safety / Encapsulated 316L SS (EN/IEC 60079-0+7+18+31)*	-	-	-	●
W	S	E	M				Waterproof IP66/67 - 316 SS enclosure (EN/IEC 60079-7,-18 and -31)*	-	-	-	●
W	S	N	F				Flameproof - 316L SS (EN/IEC 60079-1, 60079-31)*	-	-	-	●
						X	Threaded conduit (1/2" NPT)	-	-	-	●
						X	Other special constructions	-	-	-	●

\* ATEX/IECEx valves using these solenoids are approved according to EN 13463-1 (non electrical)

## SUFFIX TABLE

suffix					description	power level			
1	2	3	4	5		LP	RP	MP	BP
V					FPM (fluoroelastomer)	-	-	-	●
	C	O			Epoxy coating on all external surfaces	-	-	-	●
			M	O	Push type manual operator <sup>(2)</sup>	-	-	-	●
			M	S	Screw type manual operator <sup>(1)(2)</sup>	-	-	-	●

● Available feature ○ Available feature in DC only - Not available

<sup>(1)</sup> Functional Safety certification is not applicable with this feature

<sup>(2)</sup> Under pressure removable execution (see page 5)

## OPTIONS & ACCESSORIES

catalogue number	spare part kit no. <sup>(2)</sup>	mounting bracket
	~ / =	
SC ❖327A605	C117638	■
SC ❖327A606	C117638	■
SC ❖327A607	C117640	■
SC ❖327A608	C117640	■
SC ❖327A609	C117640V	■
SC ❖327A610	C117640V	■
SC ❖327A645	C117638	■
SC ❖327A646	C117638	■
SC ❖327A647	C117640	■
SC ❖327A648	C117640	■
SC ❖327A649	C117640V	■
SC ❖327A650	C117640V	■

❖ Select 8 for NPT ANSI 1.20.3 or select G for ISO G(228/1)

<sup>(2)</sup> Standard prefixes/suffixes are also applicable to kits

■ Mounting holes in body

## ORDERING EXAMPLES VALVES:

SC 8 327A607 24V / DC
WSEMT G 327A608 MS 24V / DC
NFET G 327A607 230V / 50 Hz
WSCREM G 327A608 MS 24V / DC
NF 8 327A645 24V / DC
WS G 327A648 MS 24V / DC
EM 8 327A607 230V / 50 Hz
WSNF G 327A608 MS 24V / DC

prefix — pipe thread — basic number — voltage — suffix

## ORDERING EXAMPLES KITS:

C117640 <sup>(1)</sup>
WSEM C117640 MS
NF C117640
WSEM C117640 MS

prefix — basic number — suffix

<sup>(1)</sup> Basic kit number applies to SC coil construction

## PRODUCT SELECTION GUIDE

### STEP 1

Select the fluid temperature range and seal material from the general table on page 1. Select, based on the selected seal material (if applicable), the basic catalogue number. Also select the pipe thread identification letter.

**Example: G327A607**

### STEP 2

Select prefix (combination): Select the appropriate operator from the prefix table on the left. Select for this operator in the electrical characteristics table on page 3: the power level (LP,RP,MP,BP) the type of electrical enclosure protection and the desired temperature class.

**Warning: the ambient temperature range of your application may not exceed the temperature range of your operator** (see also on page 3 the section: Explanation of temperature ranges of solenoid valves).

**Example: SC G327A607**

### STEP 3

Select suffix (combination) if required. Refer to the suffix table on the left.

**Example: VMS**

### STEP 4

Select voltage. Refer to standard voltages on page 3.

**Example: 230V / 50Hz**

### STEP 5

Final catalogue / ordering number.

**Example:**

**SC G327A607 VMS 230V / 50 Hz**

**EXPLANATION OF TEMPERATURE RANGES OF SOLENOID VALVES**

Valve temperature range                      The valve temperature range (TS) is determined by the selected seal material, the temperature range for proper operation of the valve and sometimes by the fluid (e.g. steam)

Operator ambient temperature range        The operator ambient temperature range is determined by the selected power level and the safety code

Total temperature range                      The temperature range of the complete solenoid valve is determined by the limitations of both temperature ranges above

**ELECTRICAL CHARACTERISTICS**

**Coil insulation class**                      H

**Electrical safety**                            IEC 335

**Standard voltages**                         DC (=) 24V - 48V; Allowable voltage variation ± 10%

   AC (~) 24V - 48V - 115V - 230V/50/60Hz; Other voltages are available on request

prefix option	power ratings				operator ambient temperature range (C°) <sup>(1)</sup>	safety code	electrical enclosure protection (EN 60529)	replacement coil / kit		type <sup>(2)</sup>
	inrush ~	holding ~	hot/cold =	=				24V/DC		
	(VA)	(VA)	(W)						(W)	
<b>Basic power (BP)</b>										
SC	10,0	10,0	10,0	9/10	-40 to +60	EN 60730	IP65, moulded	400924-197	400923-342	01
SC	14,1	14,1	14,1	11/14	-40 to +90	EN 60730	IP65, moulded	400924-697	400923-642	01
WP/WS	10,0	10,0	10,0	9/10	-40 to +60	EN 60730	IP67, steel /SS	400921-197	400911-342	02
WP/WS	14,1	14,1	14,1	11/14	-40 to +90	EN 60730	IP67, steel /SS	400921-697	400911-642	02
WSCR	8,0	8,0	8,0	6,4/8	-60 to +25/40/60	II2G Ex d IIC Gb T6/T5/T4, II2D Ex t IIIC Db	IP66/67, SS	400962-497	400961-042	04
WSCR	10,0	10,0	10,0	9/10	-60 to +25/60/90	II2G Ex d IIC Gb T5/T4/T3, II2D Ex t IIIC Db	IP67, alu./SS	400962-197	400961-342	04
NF/WSNF	10,0	10,0	10,0	9/10	-60 to +40/60	II2G Ex d IIC Gb T6/T5, II2D Ex tb IIIC Db	IP66/67, alu./SS	400921-197	400911-342	03
NF/WSNF	14,1	14,1	14,1	11/14	-60 to +40/60/90	II2G Ex d IIC Gb T6/T5, II2D Ex tb IIIC Db	IP66/67, alu./SS	400921-697	400911-642	03
WSCREM	8,0	8,0	8,0	6,4/8	-60 to +25/40/60	II2G Ex e mb IIC Gb T6/T5/T4, II2D Ex tb IIIC Db	IP66/67, SS	400962-497	400961-042	04
WSCREM	10,0	10,0	10,0	9/10	-60 to +25/60/90	II2G Ex e mb IIC Gb T5/T4/T3, II2D Ex tb IIIC Db	IP66/67, SS	400962-197	400961-342	04
EM/WSEM	10,0	10,0	10,0	9/10	-40 to +40/60	II2G Ex e mb IIC Gb T4/T3, II2D Ex tb IIIC Db	IP66/67, steel /SS	400921-197	400911-342	02
EM/WSEM	14,1	14,1	14,1	11/14	-40 to +40	II2G Ex e mb IIC Gb T3, II2D Ex tb IIIC Db	IP66/67, steel /SS	400921-697	400911-642	02

<sup>(1)</sup> Temperature range can be limited by sealings    <sup>(2)</sup> Refer to the dimensional drawings on page 4 and 5    <sup>(3)</sup> Multiple coil kits are available under ATEX/IECEX, contact us - Not available

**ELECTRICAL CONNECTIONS**

prefix	connection
SC	Spade plug connector with cable gland EN175301-803A (ISO 4400) for cables with an outer diameter from 6 to 10 mm
WP, WS, EM, WSEM	M20 plastics cable gland for cables with an outer diameter from 7 to 12 mm.
WSCREM	M20 316 SS cable gland for cables with an outer diameter from 7,2 to 11,7 mm.
NF, WSNF, WSCR	1/2" NPT threaded cable entry. Enclosures are supplied without cable gland
NFET, WSNFET	M20 x 1,5 threaded cable entry. Enclosures are supplied without cable gland

**ADDITIONAL OPTIONS**

- Manual operator MO (push type) and MS (screw type)
- 3/8" pipe thread execution
- 1/2" NPT (prefix "T") and M20 x 1,5 (prefix "ET") conduits (aluminium or 316 SS) available for steel solenoid housing
- Solid state components for peak voltage suppression and/or rectification
- For manual reset type see page PIC-11-25
- Manual Operators are available as shown on page 5

**INSTALLATION**

- Multi language installation/maintenance instructions are included with each valve
- The solenoid valves can be mounted in any position without affecting operation
- The mounting holes are provided in the valve body
- Threaded pipe connection identifier is 8 = NPT (ANSI 1.20.3); G = G (ISO 228/1)
- Declarations of conformity are available on request

### DIMENSIONS (mm), WEIGHT (kg)



**TYPE 01:**  
Epoxy moulded  
SC: IEC 335 / ISO 4400

327A605 / A606 / A607 / A608 / A609 / A610  
327A645 / A646 / A647 / A648 / A649 / A650

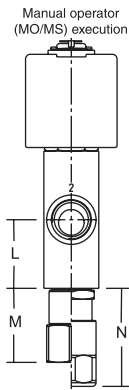
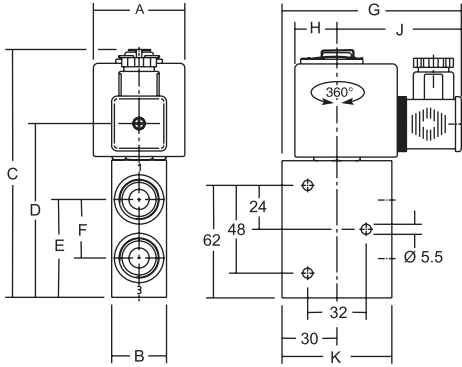

**TYPE 02:**  
Metal, epoxy coated / AISI 316 SS  
WP / WS: IEC 335  
EM / WSEM: EN/IEC 60079-7+18+31

327A605 / A606 / A607 / A608 / A609 / A610  
327A645 / A646 / A647 / A648 / A649 / A650

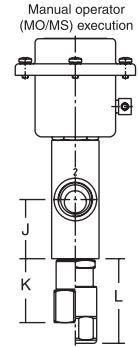
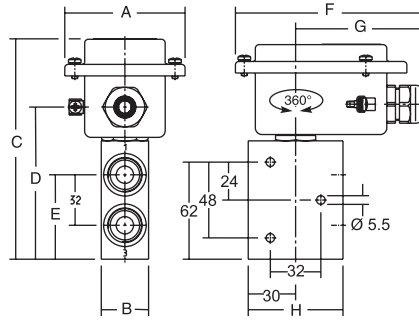

**TYPE 03:**  
Aluminium, epoxy coated / AISI 316L SS  
NF / WSNF: EN/IEC 60079-1+31

327A605 / A606 / A607 / A608 / A609 / A610  
327A645 / A646 / A647 / A648 / A649 / A650

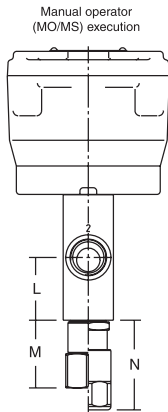
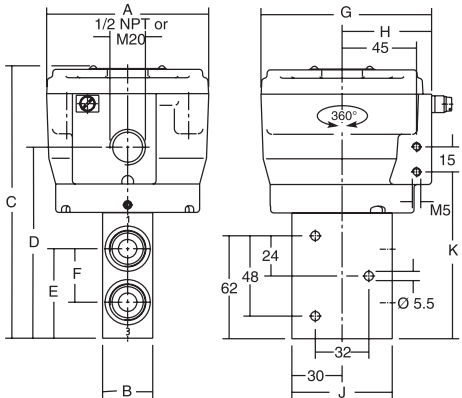

**TYPE 04:**  
AISI 316L SS  
WSCR : EN/IEC 60079-0, 60079-1, 60079-31  
WSCREM : EN/IEC 60079-0, 60079-7, 60079-18,  
EN/IEC 60079-31

327A605 / A606 / A607 / A608 / A609 / A610  
327A645 / A646 / A647 / A648 / A649 / A650

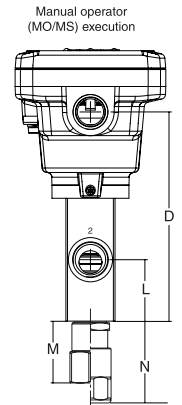
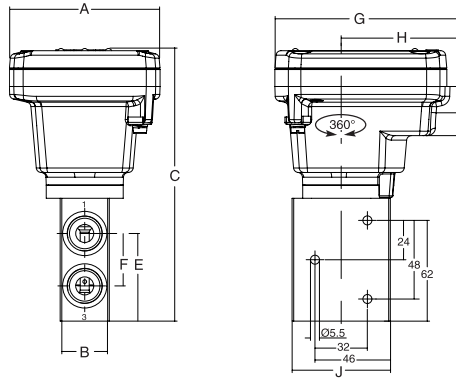

type	prefix/option	power level	A	B	C	D	E	F	G	H	J	K	L	M	N	weight
01	SC	BP	50	30	135	95	54	32	100	23	70	60	38	40	54	1,6 kg
02	WP, WS, EM/WSEM	BP	75	30	140	95	54	120	80	60	38	40	54	-	-	1,6 kg
03	NF	BP	97	30	165	115	54	32	102	55	60	100	38	40	54	2,4 kg
	WSNF	BP	97	30	165	115	54	32	102	55	60	100	38	40	54	3,8 kg
04	WSCR, WSCREM	BP	92	30	167	128	54	32	116	75	60	-	38	40	54	3,2 kg

**SECTIONAL DRAWINGS**

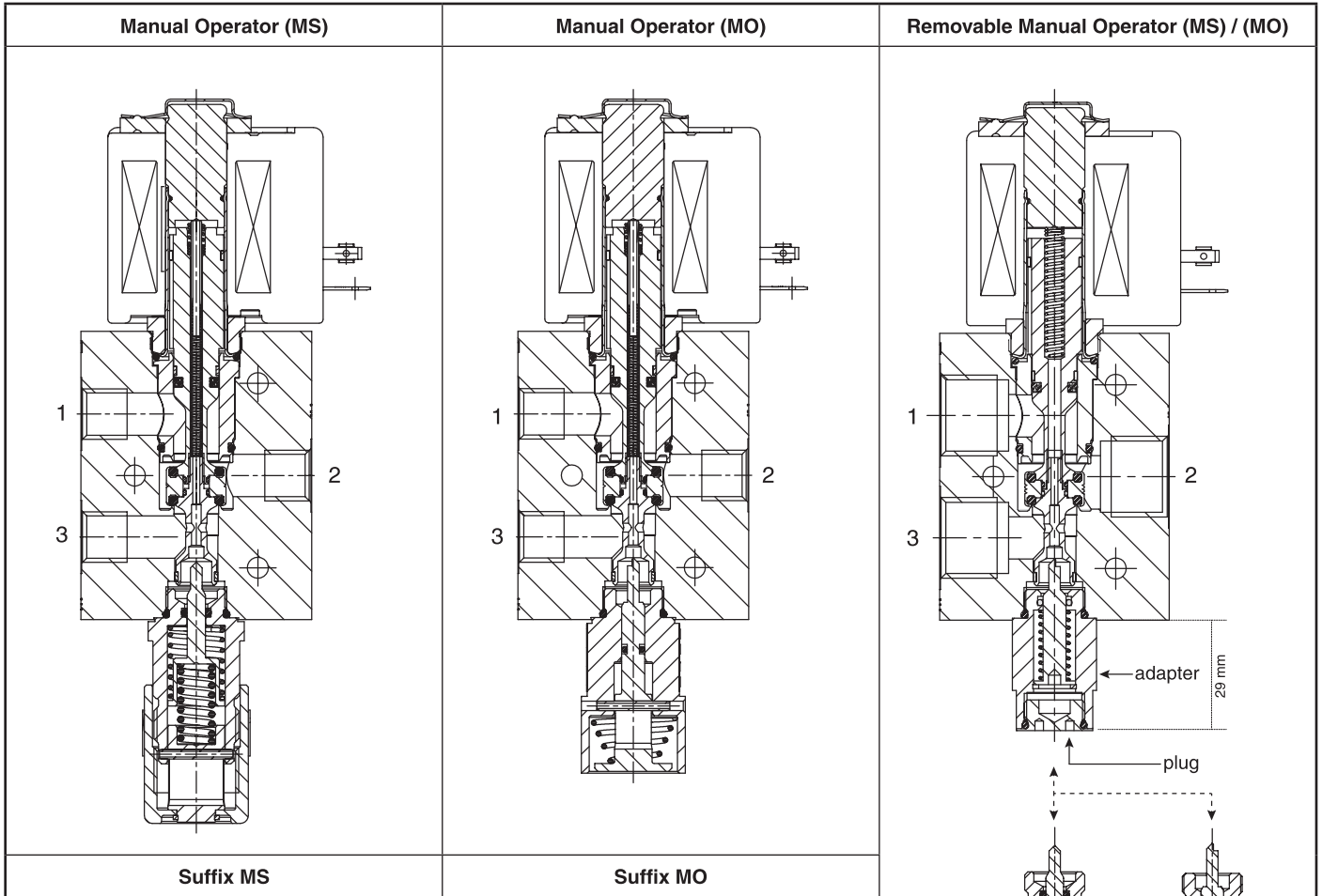

**REMOVABLE MO / MS TOOL**

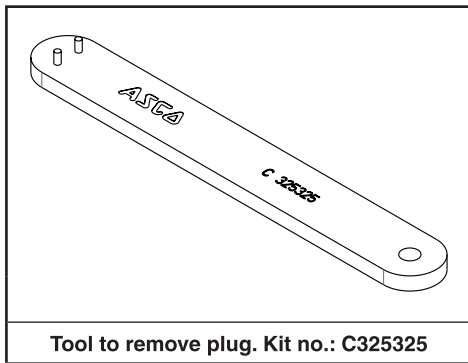

**Mounted adapter use TPL 26710**

Removable Manual Operator	Kit number
MS type	C325324
MO type	C325323
Adapter type	C325410

**EXHAUST PROTECTOR**

pipe size	thread	part number		mesh/filtering	wrench size (REF A.)	
		brass nickel plated	316L stainless steel			
1/4	ISO 228/1	131875-001	131875-014	100 - 200 µm	16 mm	
	NPT	131875-002	131875-015			
1/2	ISO 228/1	131875-005	131875-012	100 - 200 µm	23 mm	
	NPT	131875-006	131875-013			

