

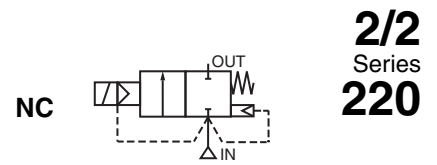

# SOLENOID VALVES

pilot operated, floating piston  
for hot water/steam applications  
3/8 to 2



## FEATURES

- Small compact sized valves particularly designed for hot water and steam, compatible with the seal materials used
- Lightweight stamped steel pistons giving all-round support to resilient, tight seal discs
- Valves require a minimum operating pressure of 0,35 bar
- All products are covered by the Pressure Equipment Directive 97/23/EC and are suitable for group 1 and 2 fluids
- The solenoid valves satisfy all relevant EC Directives

## GENERAL

**Differential pressure** See "SPECIFICATIONS" [1 bar = 100 kPa]  
**Response times** 40 - 120 ms

fluids (*)	temperature range (TS)	seal materials (*)
hot water, steam	- 20°C to + 150°C	EPDM (ethylene propylene)
steam	- 20°C to + 184°C	PTFE



## MATERIALS IN CONTACT WITH FLUID

(\*) Ensure that the compatibility of the fluids in contact with the materials is verified

<b>Body</b>	Brass
<b>Core tube</b>	Stainless steel
<b>Core and plugnut</b>	Stainless steel
<b>Springs</b>	Stainless steel
<b>Seat</b>	Brass
<b>Seals</b>	EPDM
<b>Discs</b>	EPDM or PTFE
<b>Shading coil</b>	Copper

## ELECTRICAL CHARACTERISTICS

<b>Coil insulation class</b>	F (EPDM disc) or H (PTFE disc)
<b>Connector</b>	Spade plug (cable Ø 6-10 mm)
<b>Connector specification</b>	ISO 4400 / EN 175301-803, form A
<b>Electrical safety</b>	IEC 335
<b>Electrical enclosure protection</b>	Moulded IP65 (EN 60529)
<b>Standard voltages</b>	DC (=) : 24V - 48V
(Other voltages and 60 Hz on request)	AC (~) : 24V - 48V - 115V - 230V / 50 Hz

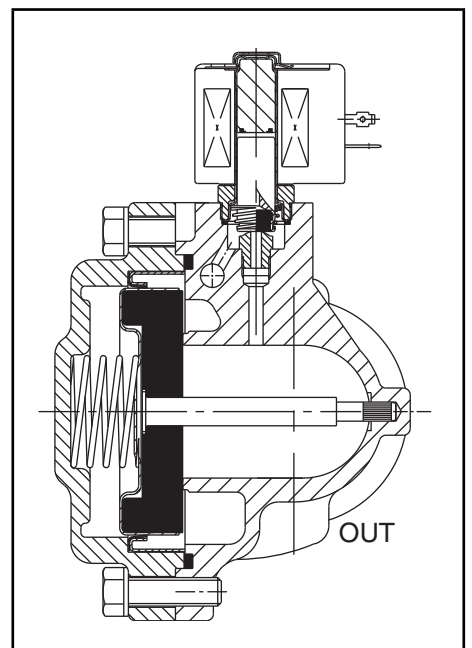

prefix option	power ratings				operator ambient temperature range (TS) (C°)	replacement coil		type <sup>(1)</sup>
	inrush	holding		hot/cold		~	=	
	~	~	=	=		230 V/50 Hz	24 V DC	
SC	55	23	10,5	-	-20 to + 40	400425-117	-	01 (class F)
	44	20	10,5	-	-20 to + 40	400406-117	-	01 (class H)
	-	-	-	12/16,8	-20 to + 40	-	400625-142	02

<sup>(1)</sup> Refer to the dimensional drawings on the following page.

## SPECIFICATIONS

pipe size	orifice size	flow coefficient Kv		operating pressure differential (bar)				max. fluid temp.		power coil (W)		catalogue number	
				min.	max. (PS)			°C					
					steam (*)	water (*) <sup>(2)</sup>		~	=				~
Rp	(mm)	(m <sup>3</sup> /h)	(l/min)										
<b>NC - Normally closed, EPDM disc</b>													
3/8	16	2,6	43	0,35 <sup>(3)</sup>	3,5	-	10	-	150	-	10,5	-	SCE220A001
1/2	16	3,5	58	0,35 <sup>(3)</sup>	3,5	-	10	-	150	-	10,5	-	SCE220A003
3/4	19	4,3	72	0,35 <sup>(3)</sup>	3,5	-	10	-	150	-	10,5	-	SCE220A005
1	25	11,6	193	0,35	3,5	3,5	10	-	150	150	10,5	16,8	SCE220.007
1 1/4	28	12,8	213	0,35	3,5	3,5	10	-	150	150	10,5	16,8	SCE220.009
1 1/2	32	19,5	325	0,35	3,5	3,5	10	-	150	150	10,5	16,8	SCE220.011
2	44	37	617	0,35	3,5	3,5	8	-	150	150	10,5	16,8	SCE220.013
<b>NC - Normally closed, PTFE disc</b>													
3/8	16	2,6	43	0,35 <sup>(3)</sup>	10	-	10	-	184	-	10,5	-	SCE220A019
1/2	16	3,5	58	0,35 <sup>(3)</sup>	10	-	10	-	184	-	10,5	-	SCE220A021
3/4	19	4,3	72	0,35 <sup>(3)</sup>	10	-	10	-	184	-	10,5	-	SCE220A023
1	25	11,6	193	0,35	10	-	10	-	184	-	10,5	-	SCE220.025
1 1/4	28	12,8	213	0,35	10	-	10	-	184	-	10,5	-	SCE220.027
1 1/2	32	19,5	325	0,35	10	-	10	-	184	-	10,5	-	SCE220.029
2	44	37	617	0,35	10	-	8	-	184	-	10,5	-	SCE220.031

<sup>(2)</sup> Water temperature should not exceed 100°C.

<sup>(3)</sup> Once opened, valve remains open till 0 kPa at inlet.

### OPTIONS

- Waterproof enclosure with embedded screw terminal coil according to protection class IP67, CEE-10
- Compliance with "UL", "CSA" and other local approvals available on request
- Coils according to "CSA/SA" standards
- Mounting brackets, suffix MB
- Other pipe connections are available on request
- Plug with visual indication and peak voltage suppression or with cable length of 2m (see Solenoids, Coils & Accessories section)

### INSTALLATION

- The solenoid valves can be mounted in any position without affecting operation
- Pipe connection identifier is E = Rp (ISO 7/1)
- Installation/maintenance instructions are included with each valve

### SPARE PARTS KIT & ACCESSORIES

catalogue number	spare parts kit n°.		mounting bracket n°.
	~	=	
SCE220A001/003	C310635	-	038713-000
SCE220A005	C310716	-	038713-000
SCE220.007/009	C304394	C132651	-
SCE220.011	C304395	C132652	-
SCE220.013	C304943	C132652	-
SCE220A019/021	C312712	-	038713-000
SCE220A023	C312702	-	038713-000
SCE220.025/027	C304392	-	-
SCE220.029	C304393	-	-
SCE220.031	C306807	-	-

- Not available.

### ORDERING EXAMPLES:

SC	E	220	A	001	230V / 50 Hz
SC	E	220	.	007	115V / 50 Hz
SC	E	220	.	009	24V / DC
SC	E	220	A	023	230V / 50 Hz

prefix      pipe thread      basic number      voltage      suffix

### ORDERING EXAMPLES KITS:

C310635	
C132651	

basic number      suffix

### DIMENSIONS (mm), WEIGHT (kg)



**TYPE 01**  
Prefix "SC" Solenoid  
Epoxy moulded  
IEC 335 / ISO 4400  
IP65

SCE220A001/003/005/019/021/023

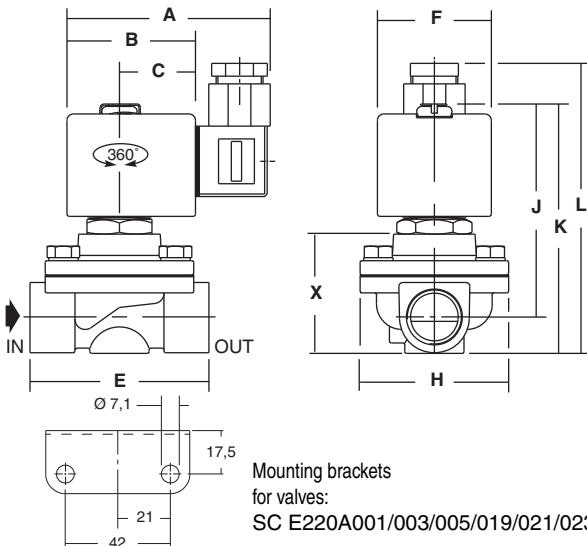

**TYPE 01-02**  
Prefix "SC" Solenoid  
Epoxy moulded  
IEC 335 / ISO 4400  
IP65

Type 01 (AC): SCE220.007/009/011/013/025/027/029/031  
Type 02 (DC): SCE220.007/009/011/013

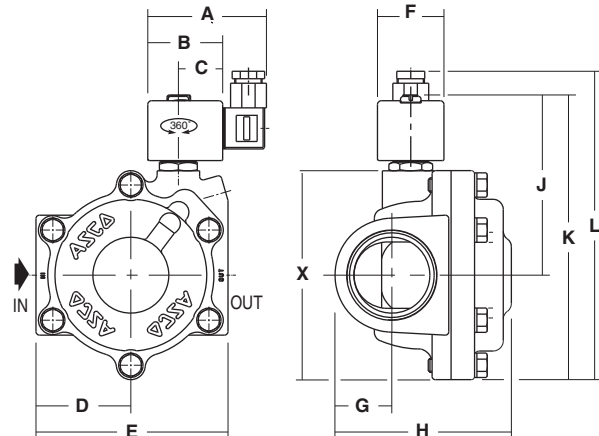

type	prefix option	catalogue number	A	B	C	D	E	F	G	H	J	K	L	X	weight <sup>(1)</sup>
01	SC	SCE220A001/003/019/021	80	50	30	-	70	45	-	58	88	102	119	53	0,9
		SCE220A005/023	80	50	30	-	73	45	-	58	92	109	122	59	1,0
		SCE220.007/025	80	50	30	47	95	45	25	78	106	147	162	98	1,8
		SCE220.009/027	80	50	30	46	93	45	29	89	106	147	162	98	2,1
		SCE220.011/029	80	50	30	55	111	45	33	104	110	160	175	111	2,8
		SCE220.013/031	80	50	30	64	129	45	38	119	120	190	205	141	4,6
02	SC	SCE220.007	86	56	33	47	95	50	25	78	96	137	152	98	2,1
		SCE220.009	86	56	33	46	93	50	29	89	96	137	152	80	2,2
		SCE220.011	86	56	33	55	111	50	33	104	100	150	165	93	2,9
		SCE220.013	86	56	33	64	129	50	38	119	110	180	195	123	4,7

<sup>(1)</sup> including coil and connector.